

# NP-18SHM

## Single Header Catalytic Bead (Pellistor) Gas Sensor

D53346 rev.4 dated 28/09/2021



### Key Features

The NP-18SHM is a catalytic (pellistor) type flammable gas sensor supplied as a matched pair of elements mounted in a single header and protected by a metal mesh enclosure.

The sensor detects and measures the presence of flammable gases and vapours in air, in the range 0-60% of the Lower Explosive Limit (LEL) of the gas or vapour being measured. Designed as a lower cost alternative to the twin-header NP-18SMM device, the NP-18SHM may be used as the sensing platform in fixed flammable gas detection systems.

The NP-18SHM exhibits excellent long term zero and sensitivity stability and a high level of resistance to catalytic poisons. The highly automated manufacturing procedure employed results in a repeatable reliable sensor which, unlike similar devices, requires no trimming resistor to enable the detector to be matched with a compensator.

### NET Catalytic Bead Pellistors

Our Pellistor, or catalytic bead sensor, line is selected by N.E.T. and manufactured, on OEM basis, by world's best manufacturers.

The sensor monitors the presence of a combustible gas or vapor in air (or atmospheres containing oxygen) up to the Lower Explosive Limit (LEL). A Pellistor operates on the principle that when a combustible gas/air mixture is in contact with the catalyst surface, maintained at about 500°C as current is passed through it in a Platinum coil, combustion occurs. The heat generated increases the temperature of the bead, which in turn changes the resistance of the coil. The resistive signal change produced is proportional to the gas concentration and can be measured by using the coil as a temperature thermometer in a standard Wheatstone bridge circuit.

Given Pellistors capacity to ignite flammable gas mixtures, is typically necessary to encapsulate the beads in a certified flameproof enclosure, such as N.E.T. Certified

Heads. This will allow the beads to be exposed to the target gas without the risk of ignition.

Pellistors are an inexpensive and effective solution to monitor Methane (CH<sub>4</sub>) and other Hydrocarbons and, generally, combustible gases such as Hydrogen (H<sub>2</sub>) and Ammonia (NH<sub>3</sub>). They offer very low humidity and temperature dependence.

As their measurement principle is based on combustion, Pellistors cannot be used in inert atmospheres and require the presence of Oxygen. Additionally, they are susceptible to inhibition and poisoning by chemicals such as Lead- and Sulphur-containing compounds, phosphates and organic silicones. In case any of those two risks are present, try our InfraRed sensors.

The standard dimensions and the electrical output make our Pellistor perfectly compatible with a wide range of commercially available Gas Detection Systems and remote flammable gas detector heads.

## Mechanical specifications

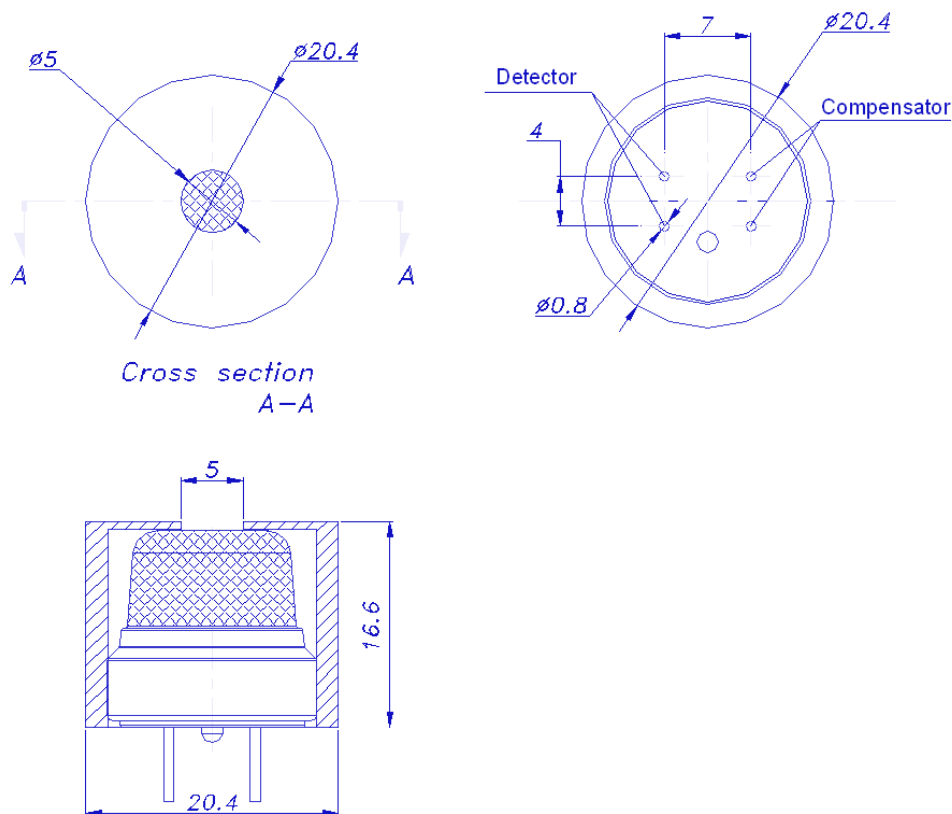

## Product specifications

Technical Specifications	Recommended Voltage:	2.5 V $\pm$ 0.1 V
	Current Drawn:	180 $\pm$ 20mA
	Zero Offset:	0mV $\pm$ 30mV
	Sensitivity:	40-70 mV/% CH4/Air
	Range:	0-100% LEL
	Linearity:	Effectively Linear to 60% LEL
	Accuracy:	$\pm$ 1%LEL(CH4)
	Maximum Long Term Drift (Span):	< $\pm$ 2% LEL/ Month
	Maximum Long Term Drift (Zero):	< $\pm$ 0.5 mV/Month
	Response Time:	T50: 6.5 sec T90: 20 sec
Operating conditions	Operating Temperature:	-20C to + 70°C
	Temperature Drift (Zero): (-20°C to +70°C)	< +/- 2% LEL
	Operating Humidity:	0-100% RH, non-condensing
	Humidity Response:	+/- 2% LEL

## Recommended circuit

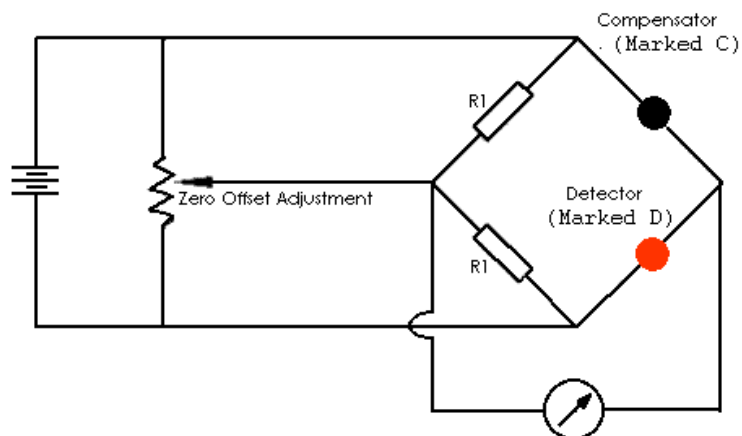

## Gas Sensitivity/Linearity

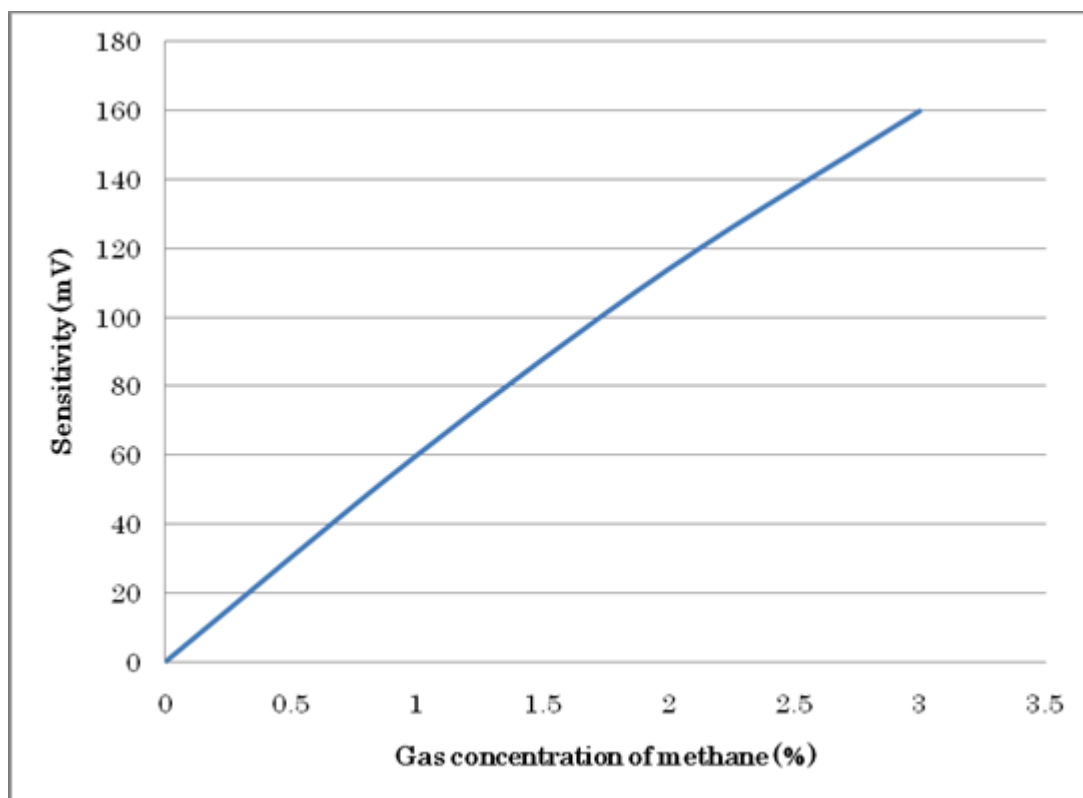

## Temperature dependency

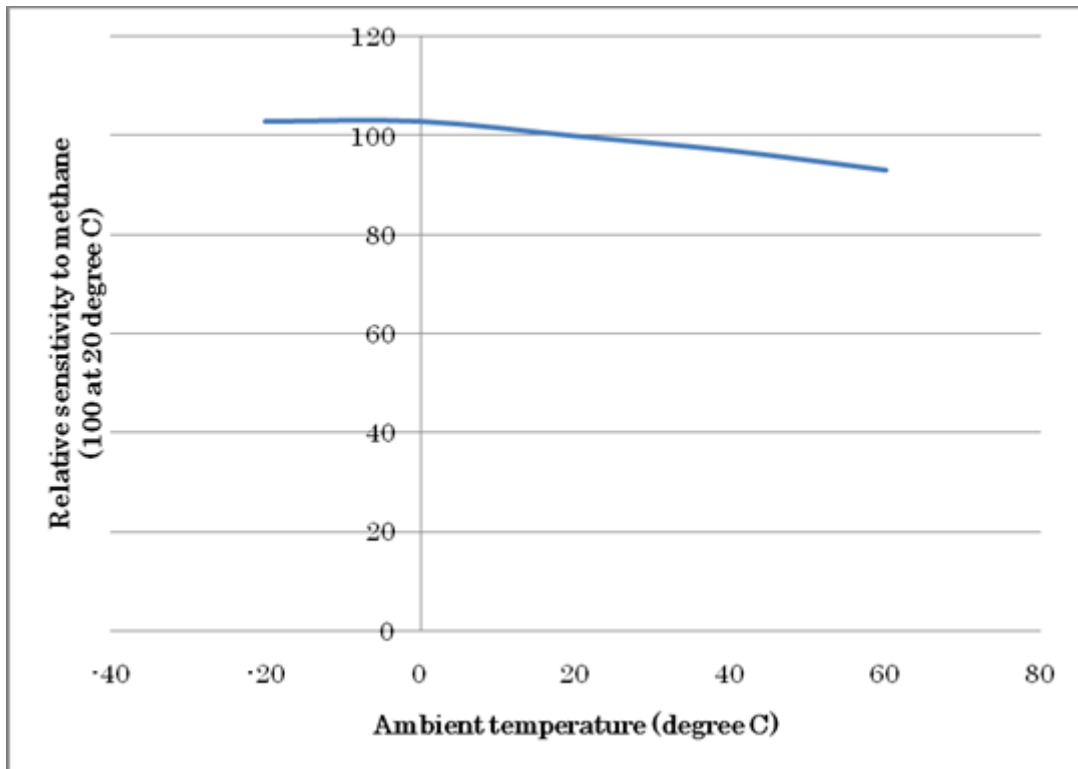

## Temperature dependency

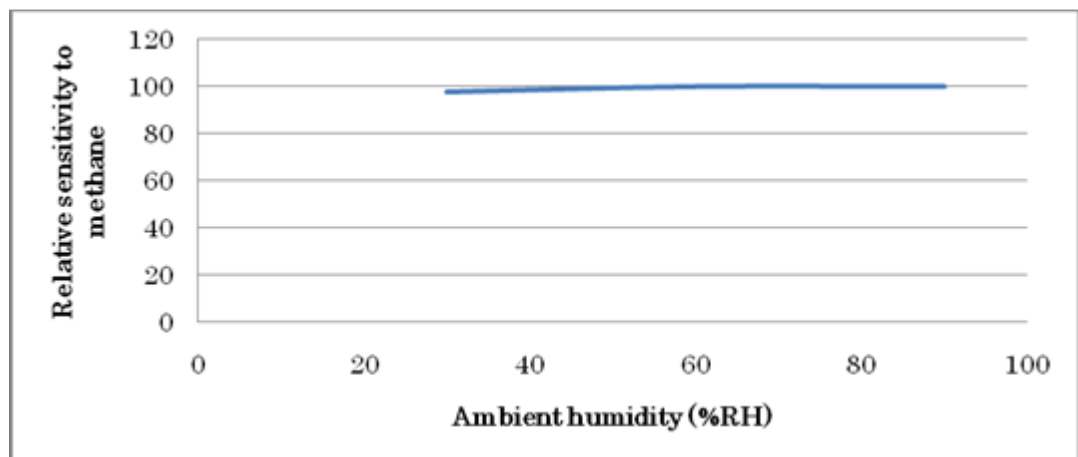

## Relative response to various gases

Below is a table of NP-17SHM responses to various flammable gases. The table assumes the sensor is measuring on the 0-100% LEL scale and assumes that the response to methane = 100%.

Note that the LEL data can be different in different countries. In Europe, the LEL's used are defined in the IEC standard IEC80079-20-1, whilst in the USA and various other areas, LELs are generally taken from the US Bureau of Mines Bulletin Document 627.

Technically, both are correct; the reason for the differences being that the measurements made for IEC80079-20-1 are with the gas in motion, whilst the US Bureau of Mines Bulletin Document 627 assumes the gas is not moving.

For convenience, relative responses are given according to BOTH standards below.

Gas	Formula	LEL (Europe) (IEC80079-20-1)	Relative Response (%)	LEL (USA) (USBoM 627)	Relative Response (%)
Methane	CH <sub>4</sub>	4.4	100	5	100
Acetic acid	CH <sub>3</sub> COOH	4	11	5.4	14
Acetone	(CH <sub>3</sub> ) <sub>2</sub> CO	2.5	51	2.6	47
Cyclo-hexane	C <sub>6</sub> H <sub>12</sub>	1	52	1.3	60
Cyclo-pentane	C <sub>5</sub> H <sub>10</sub>	1.4	68	1.5	64
Ethanol	C <sub>2</sub> H <sub>5</sub> OH	3.1	55	3.3	52
Ethyl acetate	C <sub>2</sub> H <sub>5</sub> COOH	2	49	2.2	47
Ethylene	C <sub>2</sub> H <sub>4</sub>	2.3	77	2.7	80
Hydrogen	H <sub>2</sub>	4	119	4	105
Iso-butane	C <sub>4</sub> H <sub>10</sub>	1.3	53	1.8	65
Iso-octane	C <sub>8</sub> H <sub>18</sub>	0.7	40	Not Given	40
Iso-propanol	CH <sub>3</sub> -C <sub>2</sub> H <sub>4</sub> COOH	2	34	2.2	33
Methanol	CH <sub>3</sub> OH	6	74	6.7	73
N-butane	C <sub>4</sub> H <sub>10</sub>	1.4	60	1.8	68
N-heptane	C <sub>7</sub> H <sub>16</sub>	0.85	48	1.05	53
N-hexane	C <sub>6</sub> H <sub>14</sub>	1	52	1.2	55
N-pentane	C <sub>5</sub> H <sub>12</sub>	1.1	54	1.4	61
Propane	C <sub>3</sub> H <sub>8</sub>	1.7	64	2.1	70
Styrene	C <sub>6</sub> H <sub>5</sub> CH=CH <sub>2</sub>	1	36	1.1	35
Toluene	C <sub>6</sub> H <sub>5</sub> CH <sub>3</sub>	1	47	1.2	50
Ammonia	NH <sub>3</sub>	15	97	15	85
Propylene	CH <sub>3</sub> -CH=CH <sub>2</sub>	2	80	2.4	84
Carbon monoxide	CO	10.9	74	12.5	75
Xylene	C <sub>6</sub> H <sub>4</sub> (CH <sub>3</sub> ) <sub>2</sub>	1	52	1.1	50
n-octane	CH <sub>3</sub> (CH <sub>2</sub> ) <sub>6</sub> CH <sub>3</sub>	0.8	45	0.95	48

## Warranty and warning

Use within specified conditions.

Sensor characteristics must be measured in clean air without noise gases.

Electrode pins must be correctly connected. Wrong connection does not allow correct functions.

Do not apply voltage directly to electrode pins.

Do not bend pins.

Do not solder to electrode pins directly. Use exclusive sockets.

Do not use contact grease on electrode pins.

Do not put excess strength on electrode pins.

If sensor housing is damaged or scratched, do not use sensor.

Do not blow organic solvents, paints, chemical agents, oils, or high concentration gases onto sensor.

Do not disassemble or change any parts.

If sensor is used under irregular atmosphere, contact us for assistance.

**N.E.T. has a policy of continuous development and improvement of its products. As such the specification for the device outlined in the data sheet may be changed without notice. In case of modification of the product, N.E.T. disclaims all liability.**

**No part of this publication may be reproduced, distributed, or transmitted in any form or by any means, including photocopying, recording, or other electronic or mechanical methods, without the prior written permission of N.E.T. For permission requests or technical support please contact or write to the address below:**



N.E.T. SRL  
Via Legnano, 2 | 20010 | Cornaredo | Milano | Italy  
T +39.02.9354.4190  
E [info@nenvitech.com](mailto:info@nenvitech.com)  
[www.nenvitech.com](http://www.nenvitech.com)