



# MEMS Analog Katharometer 20mm

## Intelligent Thermal Conductivity Hydrogen Sensor

DS5317 rev.2 dated 15/04/2026



### Key Features

- Individual calibration and testing, for measurements you can trust
- Extended temperature range (-40 °C to +60 °C), for use in any environment
- Active Environmental compensation (Temperature, RH, Pressure)
- Internal microprocessor, for advanced signal processing
- Standard industrial size, to fit existing detectors
- Low power consumption
- Fast T90 response time, for critical and life-saving applications
- Outstanding long-term stability of 1 % F.S./year
- Broadest available ranges
- ModBus digital communication, for ease of integration
- Signal versatility: voltage and optional bridge or pellistor output
- Solid, rugged construction with stainless steel enclosure
- Standard industrial accepted negative or positive pinout

### General Description

With the application of MEMS (Micro Electronic Mechanical Systems) technology, NET is making the power of thermal conductivity gas sensors available for the broadest range of Hydrogen detection applications. By employing very repeatable, high-volume CMOS (Complementary metal-oxide-semiconductor) MEMS technology, the new NET KATHAROMETER GAS TECHNOLOGY is lowering production costs and the typically high power consumption of thermal conductivity gas sensors.

MAK sensors detect hydrogen concentrations in the air by measuring the change in thermal conductivity of the gas mixture. Thermal conductivity sensors are most effective when detecting gases with low molecular weight, which correspond to greater thermal conductivity. Hydrogen possesses the highest thermal conductivity of all known gases.

Unlike catalytic bead sensors, NET MAK sensors covers the broadest range of detection, working well from ppm level, up until % volume. This is because they can operate without the presence of Oxygen. They also provide far better long-term stability than sensors that are triggered by chemical reactions that eventually cause the sensor to degrade. Thermal conductivity gas sensors, in fact, do not involve physical or chemical changes in the sensor. This, coupled with outstanding resistance to poisoning, results in far greater operating lives than for traditional technologies.

NET MAK MEMS-membrane-based sensor offers a far greater resistance to mechanical shocks when compared to catalytic or traditional thermal conductivity sensors.

Another key factor is the fast response time of the sensor, the only limiting factor being the time required for changes in the measurement resistor.

**Thermal conductivity sensors** measure the concentration of gases having thermal conductivity significantly different to a reference gas (normally, air).

A thermal conductivity gas sensor is formed by two dies – one freely exposed to the target gas (the active die) and the other sealed in a chamber containing air (the reference die). Both dies are heated using constant current and run in a classic Wheatstone bridge circuit. Thermal conductivity sensors measure the change in heat loss of the active die in the presence of the target gas. In fact, when the active die is exposed to a gas with thermal conductivity different to that of air, the rate of heat loss from the die will change and so will its resistance. This change is compared with the resistance of the reference die.

Thermal conductivity sensors are subject to specific cross sensitivity with other gases whose thermal conductivity is also significantly different from that of air. Therefore, thermal conductivity sensors perform best in applications where interfering gases are absent, or their cross sensitivity is within the required acceptable margin of error.

## Mechanical specifications

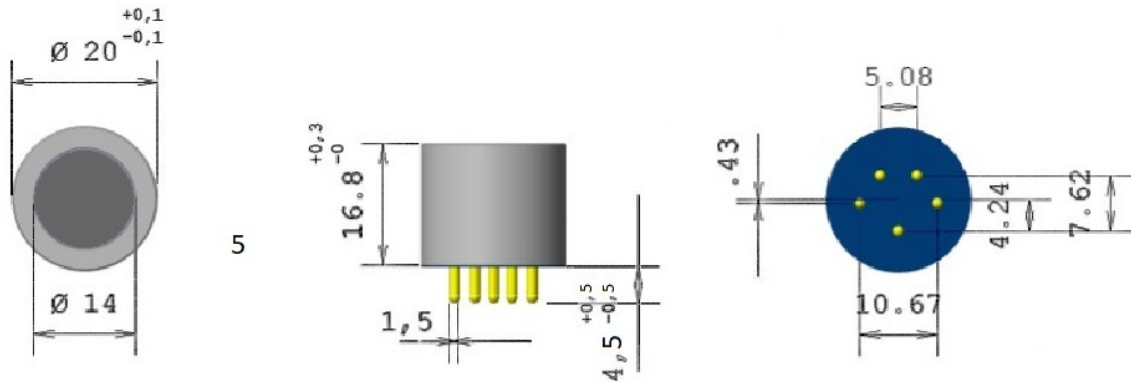

## Pinout

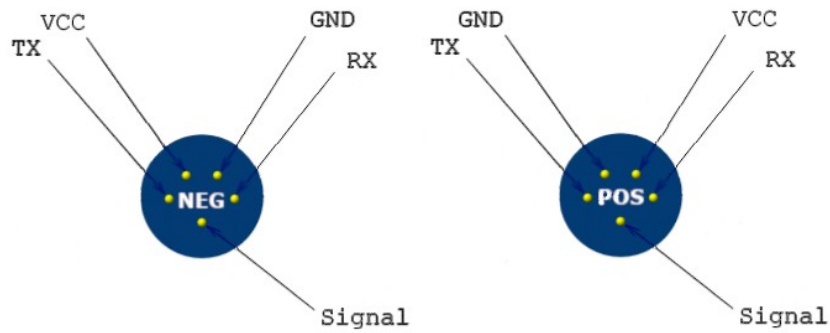

## Digital Communication

Digital Interface	Digital signal format	8 data bits, 1 stop bit, no parity
	Standard Baud rate	38400 bps as Default; 4800, 9600, 19200, bps
	TX- VOH: output "High" minimum voltage	2.4V
	TX- VOL: output "Low" maximum voltage	0.4V
	RX- VIH: input "High" minimum voltage	2V
	RX- VIL: input "Low" maximum voltage	0.8V

## Linearity

The linearity at room temperature is:  $\pm 3\%$  of FS range for readings below 50% of range and  $\pm 5\%$  of FS range above 50% of FS range.

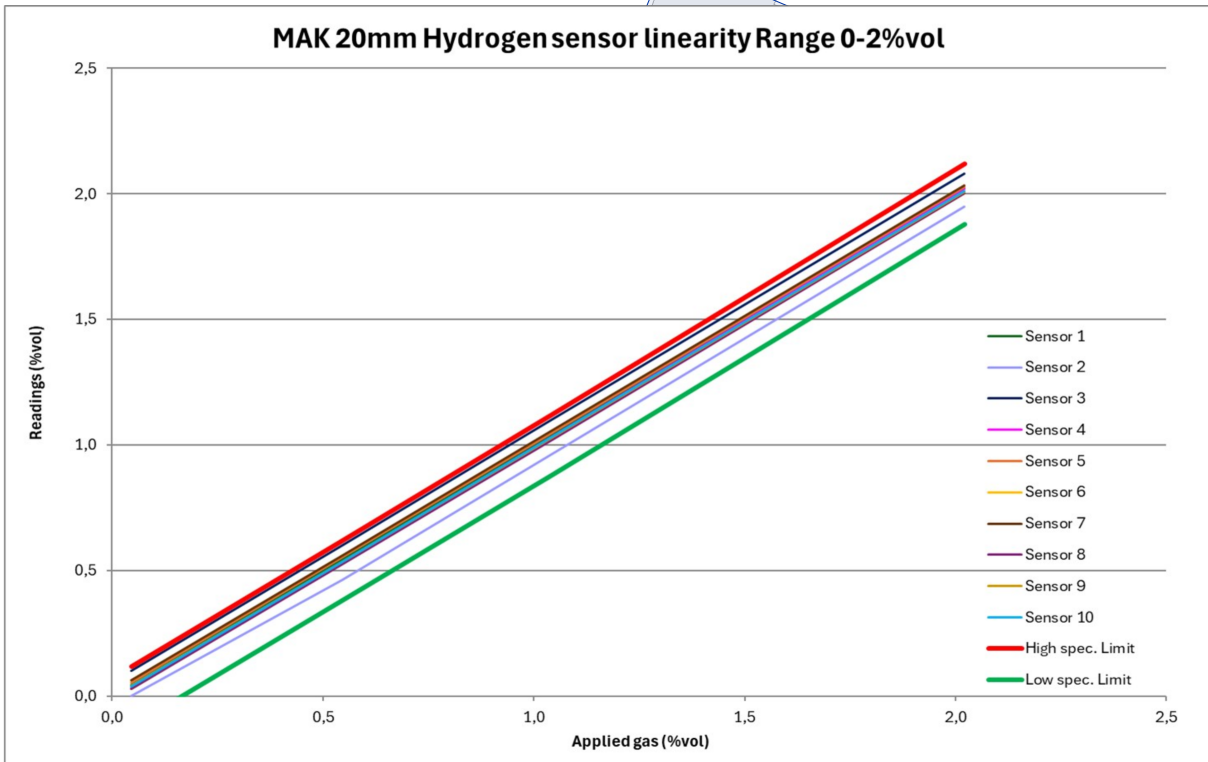

## Temperature compensation

Sensors are tested individually in climatic chambers at temperature extremes ( $-40^{\circ}\text{C}$  and  $+60^{\circ}\text{C}$ ) to adjust the internal temperature compensation. Performances in the temperature range are:  $\pm 5\%$  of FS range for readings below 50% of the range and  $\pm 7\%$  of FS range above 50% of the range.

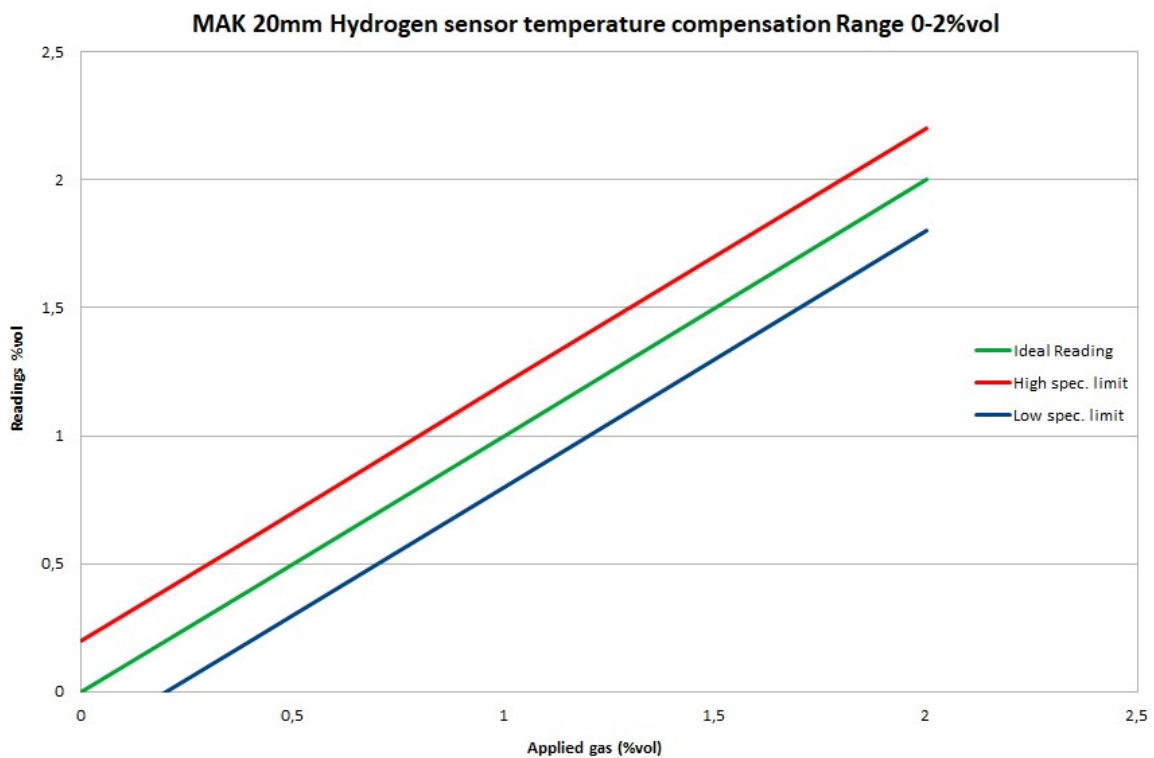

## Product specifications

General	<b>Operating temperature range</b>	-40 to +60 °C	
	<b>Storage temperature range</b>	-40 to +85 °C	
	<b>Operating humidity range</b>	0-95% Relative with maximum dew point 40°C	
	<b>Operating pressure range</b>	800-1200 mBar	
	<b>Gas types</b>	H <sub>2</sub>	
	<b>Weight</b>	14 g	
	<b>MTBF</b>	≥ 5 years	
	<b>Firmware and digital technology</b>	Designed for use in a detector that complies to EN 50271 <b>SIL2 (pending approval)</b>	
	<b>Electromagnetic Compatibility (EMC)</b>	Designed for use in a detector that complies to EN 50270	
	<b>Enclosure</b>	Stainless steel	
	<b>Calibration</b>	Individually calibrated with temperature, relative humidity and pressure compensation. Test report supplied.	
	<b>Enclosure</b>	Stainless steel	
	<b>Calibration</b>	Individually calibrated with temperature, relative humidity and pressure compensation. Test report supplied.	
	<b>Sensing method</b>	Thermal Conductivity	
Measurement	<b>Measurement range</b>	0 - 4% vol	
	<b>Repeatability</b>	±0.05% of FS range	
	<b>Accuracy*</b>	±3% of FS range below 50% of range ±5% of FS range above 50% of range	
	<b>Resolution</b>	20ppm	
	<b>Long Term Drift</b>	±1% of FS range/year	
	<b>Temperature Performance</b>	±5% of FS range below 50% of range ±7% of FS range above 50% of range	
	<b>Pressure dependence</b>	≤3%F.S	
	<b>Humidity dependance</b>	≤3%F.S	
	<b>Response time</b>	T <sub>90</sub> ≤ 20s	
	<b>Power voltage</b>	3.5 - 5.5 Vdc	
	<b>Operating current</b>	< 20 mA Idc	
	Electrical	<b>Warm up time</b>	60 s for full operation @ 25 °C At least 1 hour for full specification @ 25 °C
		<b>Max output current</b>	±7.5 mA
		<b>DC output impedance</b>	100 Ω
<b>Max capacitance load</b>		1000 pF	
Signal Output		<b>Analog output (standard for voltage mode)</b>	Standard voltage [0.4 V—2 V] dc (other voltages available on request)
	<b>Analog output (standard for bridge mode)</b>	[V <sub>cc</sub> /2 ± Δ] dc (Δ value is to be specified by the customer)	
	<b>Digital communication</b>	MODBUS protocol communication	

\*Test Conditions: Vin = 5 Vdc, Ta=25 °C, RH = 5%, 1000mbar.

## Ordering details

When making an order, we kindly ask our customers to specify the basic physical and electrical properties that are needed for their specific application. This is made through the part number here below. The squared fields of the part number below can be modified according to the options on the right.

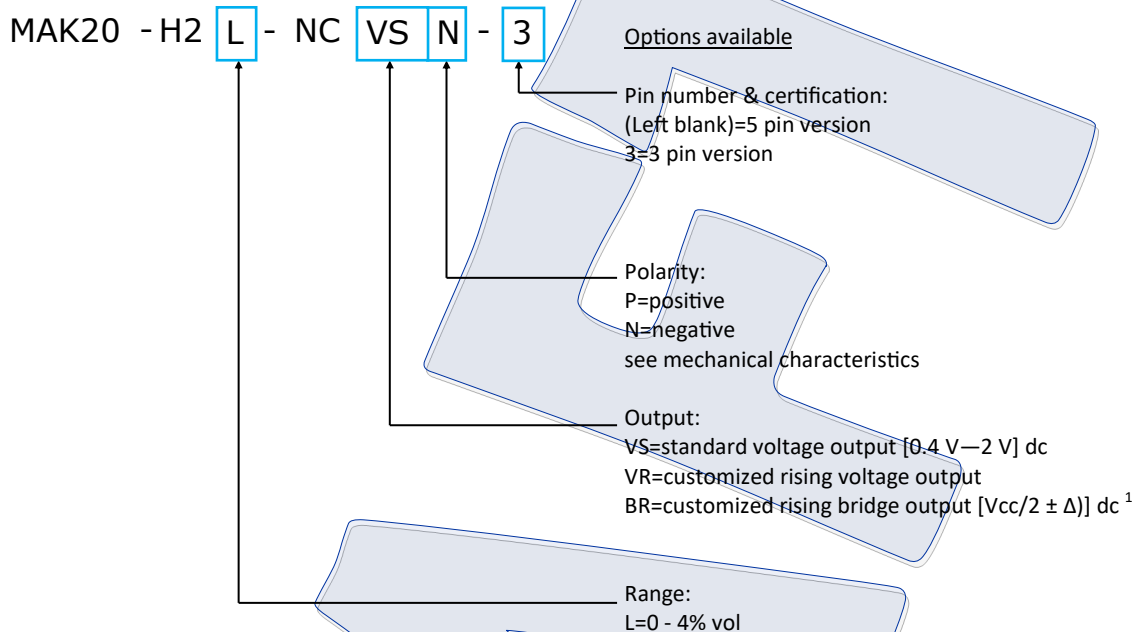

Note 1: The bridge output is indicated to use when substituting a pellistor.

## Warranty and warning

The WARRANTY of MAK 20mm sensors is 12 months from the purchased date against defects in materials or production. This warranty however is not valid for articles that have been broken, repaired by a third person or not used according to the instructions contained in this document or supplied with the products, related to the storage, installation, operation, maintenance, or servicing of the products.

Please keep particular attention to:

- Power the sensor observing the correct voltage and polarity (positive or negative)
- Never solder directly on the pin, use PCB sockets
- Never cut or remove any of the pins
- Use anti-static precautions when handling the sensor
- Never let water or other liquids to enter inside the sensor
- Never expose the sensor to corrosive gases
- The gas flow used for testing should be  $\leq 500$  SCCM
- Recalibration of the sensor will void the calibration warranty

N.E.T. has a policy of continuous development and improvement of its products. As such the specification for the device outlined in the data sheet may be changed without notice. In case of modification of the product, N.E.T. disclaims all liability.

No part of this publication may be reproduced, distributed, or transmitted in any form or by any means, including photocopying, recording, or other electronic or mechanical methods, without the prior written permission of N.E.T. For permission requests or technical support please contact or write to the address below:



N.E.T. SRL  
Via Campania, 5 | 20006 | Pregnana Milanese | Milano | Italy  
T +39.02.9354.4190  
E info@nenvitech.com  
www.nenvitech.com